

---

# Table of Contents

Subject	Page
<b>IHKA Automatic Heating and Air Conditioning System</b>	
Objectives of the Module . . . . .	2
Purpose of the System . . . . .	3
System Overview . . . . .	5
<b>Air Conditioning System</b>	
System Components . . . . .	11
Principle of Operation . . . . .	15
Workshop Hints . . . . .	17
<b>Heating System</b>	
System Components . . . . .	18
<b>IHKA Heater and Air Conditioner Housing</b>	
System Components . . . . .	19
<b>Control Panel/Control Module</b>	
Detailed Controls . . . . .	23
<b>Temperature and Air Flow Control</b>	
Principle of Operation . . . . .	27
<b>Air Distribution</b>	
Principle of Operation . . . . .	35
<b>Stationary Functions</b>	
Principle of Operation . . . . .	45
<b>Non-Air Conditioning Functions</b>	
Rear Roller Blind Control . . . . .	48
<b>Coding</b>	
Key Memory . . . . .	50
Vehicle Memory . . . . .	51
Workshop Hints . . . . .	54
<b>Review Questions</b> . . . . .	55

---

# IHKA Automatic Heating and Air Conditioning System

**Model: E65 - 745i / E66 - 745Li**

**Production Date: 11/2001 - E65, 01/2002 - E66**

## Objectives of The Module

After Completing this module, you will be able to:

- List the gasses detected by the AUC-2 sensor.
- Explain how the refrigerant compressor output is varied.
- List the refrigerant compressor "Run In" procedure.
- Locate the blower motor and blower control module.
- Describe the control panel functions.
- Explain the "Y" factor.
- Explain how the temperature is increased during air conditioning operation.
- List the functions that apply to heater operation when the coolant is cold.
- Demonstrate Manual Air Distribution individual adjustments.

# IHKA Automatic Heating and Air Conditioning System

## Purpose of The System

The E65 IHKA automatic heating and air conditioning system is designed with technological improvements and new or modified functions. The design objectives for the E65 IHKA system meets the requirements of customers worldwide for heating and cooling capability. The control display provides indication and operation.

Important primary functions are controlled by basic knobs and pushbuttons on the control panel which includes:

- Temperature control
- Blower speed
- Recirculating air
- Defrost
- Maximum Air Conditioning
- Rear window defogger
- Automatic functions

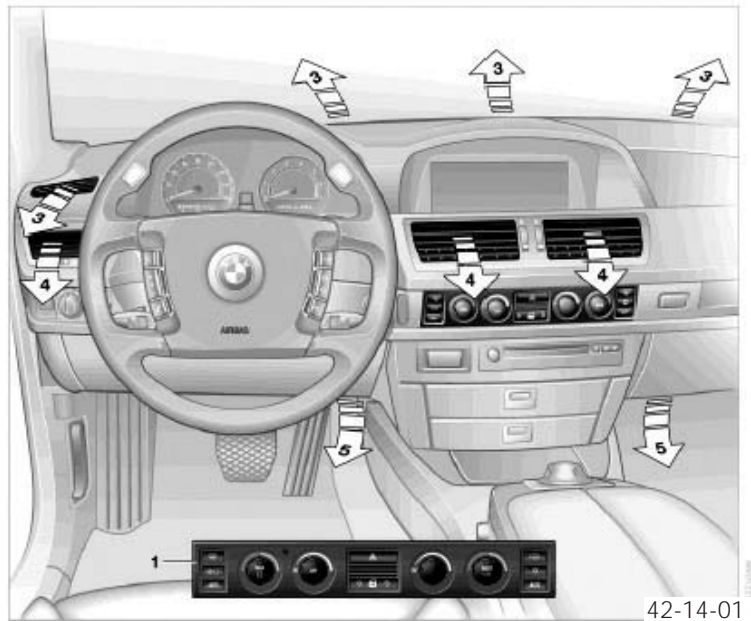

- |                                     |                           |
|-------------------------------------|---------------------------|
| 1. IHKA Control Panel/Module        | 4. Face Vent Outlets      |
| 3. Upper Air Flow Outlets (defrost) | 5. Front Footwell Outlets |

## Customer Benefits:

- Straightforward understandable operation.
- Individual adjustment is possible using the virtual controls in the control display.
- Individual settings are stored in memory.
- The rear seating area has air inlet grilles in the center console and in the B pillars.
- The design allows direct and indirect air flow to all occupants.
- Individually adjustable temperature stratification (warm/cold).
- Consideration for warm and cold air distribution (head, chest and leg regions).
- The system prevents drafts.
- Primary function controls are grouped in a single unit that is readily visible and accessible to the driver and front seat passenger.
- The temperable ventilation (air stratification) is controlled by adjusting elements in the air inlet grilles and the control display.

---

## **IHKA automatic heating and air conditioning system features:**

- Activated charcoal inlet air micro-filter
- Recirculation air filter
- Residual heat
- Independent ventilation
- AUC-2 sensor (gas sensor for automatic recirculation air control)
- 2 separate drives for outside air/recirculated air
- Air outlets in the B-pillars for rear passengers
- Solar sensor
- Vehicle and Key Memory for blower and temperature
- Dual temperature control (left/right)
- Automatic air distribution
- Air flow control
- Ventilation temperature stratification using the Controller in the Control Display menu
- Rear seat ventilation temperature control by the knurled knobs

## **E65 innovations:**

### ***Refrigerant Circuit***

- Clutch-less refrigerant compressor is regulated externally by a pulse width modulation (PWM signal).
- Dryer integrated into condenser.

### ***Heater Circuit***

- Auxiliary water pump is separate from dual water valve and installed in a remote position (easier to fill and bleed).
- Heater supply is from upper radiator hose for better accessibility and pressure limitation.

### ***IHKA Air Conditioner***

- Layout with offset positioned blower unit.
- Modified functionality of the flap system for air flow control and stratification.
- Blower with single fan impeller.
- Blower control module (clock regulator with K-Bus and diagnosis capabilities).
- Flap drives (stepper motors) with blockage recognition.

## System Overview

The heating and air conditioning system spans the entire vehicle. The major component locations including the optional rear air conditioner (E66) with cooler box is shown below.

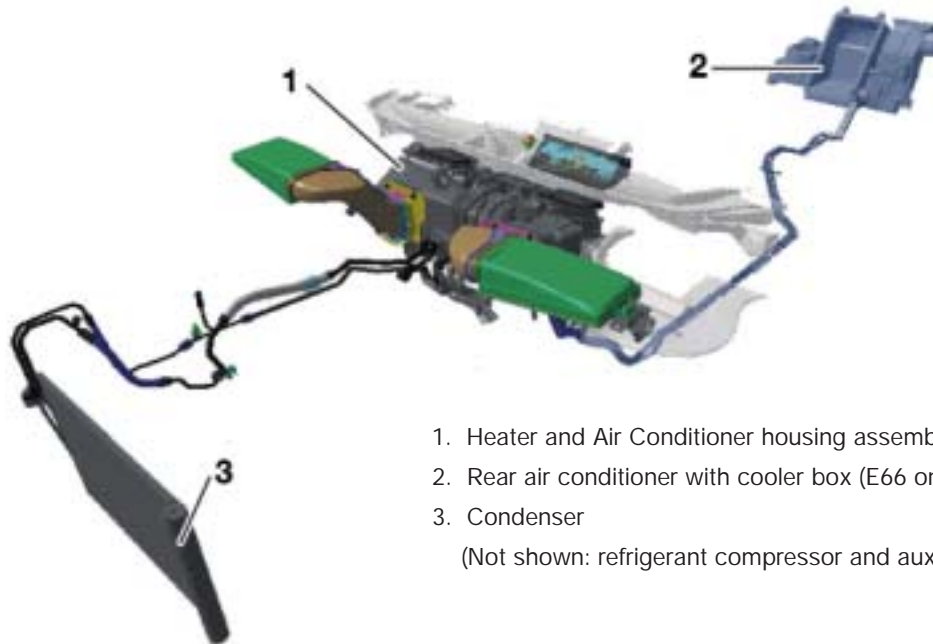

1. Heater and Air Conditioner housing assembly
  2. Rear air conditioner with cooler box (E66 only)
  3. Condenser
- (Not shown: refrigerant compressor and auxiliary fan)

KT-7780

## Overview of System Components

**Refrigerant System:** The refrigerant system components include the following:

1. Auxiliary fan with shroud
2. Condenser (2a) with integrated dryer (2b)
3. Refrigerant compressor
4. Pressure sensor (in the line)
5. Fill adapter pipe
6. Interface connection at bulkhead
7. Evaporator (inside the housing)
8. Shutoff valve (rear AC - E66)
9. Expansion valve
10. Pressure and suction lines for IHKA

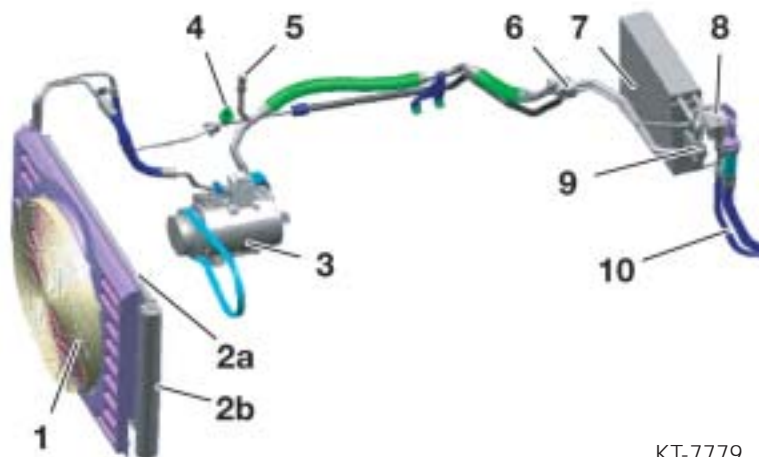

KT-7779

The layout includes two shutoff valves (one at the front for IHKA and one at the rear for E66 IHKA) and an additional evaporator with expansion valve. **R134a refrigerant** is used in the E65. The system capacity is **1.78 +/- .02 lbs (810 +/- 10 grams)**.

**Heating System:** Components of the heating circuit (coolant) with the N62 engine include:

1. Return hose
2. Heat exchanger
3. Supply hose
4. Supply hose
5. Dual water valves
6. Electric auxiliary water pump
7. Supply hose
8. Hot coolant supply hose
9. Radiator

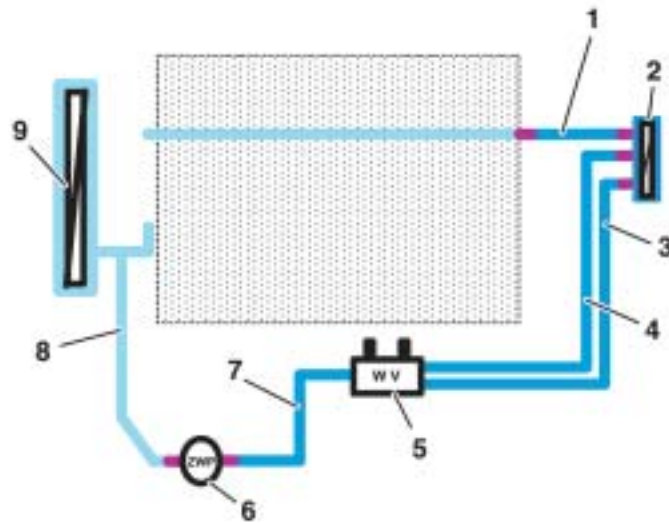

KT-8214

**Air Ducts:** Air ducts refers to all components that distribute the air supplied by the fan to the outlets. The ends of the air ducts are fitted with directional grilles.

1. Air intake/filter housing
2. Defroster ducts
3. Ventilation ducts
4. B-pillar ventilation
5. Front footwell ducts
6. Outlet ducts in the instrument panel
7. Ventilation for rear seating area
8. Heating ducts for rear seating area
9. Side window air ducts
10. Heater/Air Conditioner housing

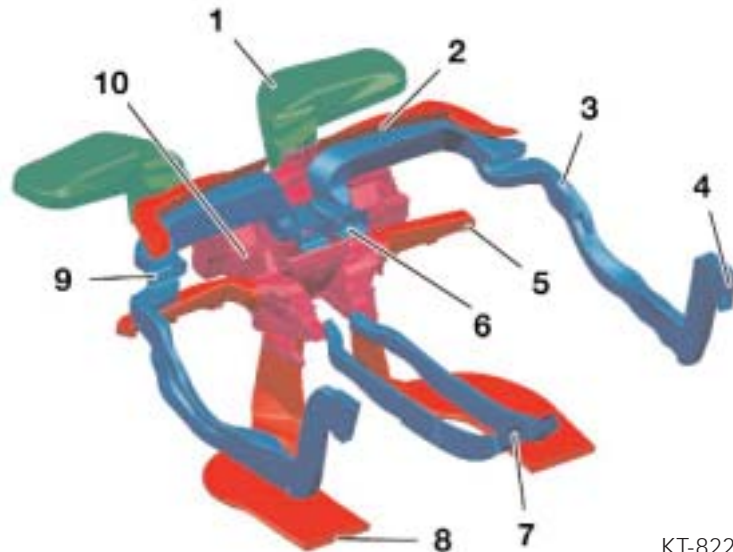

KT-8220

**Heater and Air Conditioner Housing:** The IHKA housing is secured to the middle of the engine compartment bulkhead, underneath the instrument panel. The blower is mounted inside the passenger compartment offset to the passenger's side (in front of the glovebox).

The IHKA housing is the central unit in the heating and air conditioning system, it performs the following functions:

- Create and control air flow
- Distribute the air
- Mix the air (air stratification)
- Dehumidify the air
- Convert the energy supplied by the cooling system
- Transfer the refrigeration power of the refrigerant system

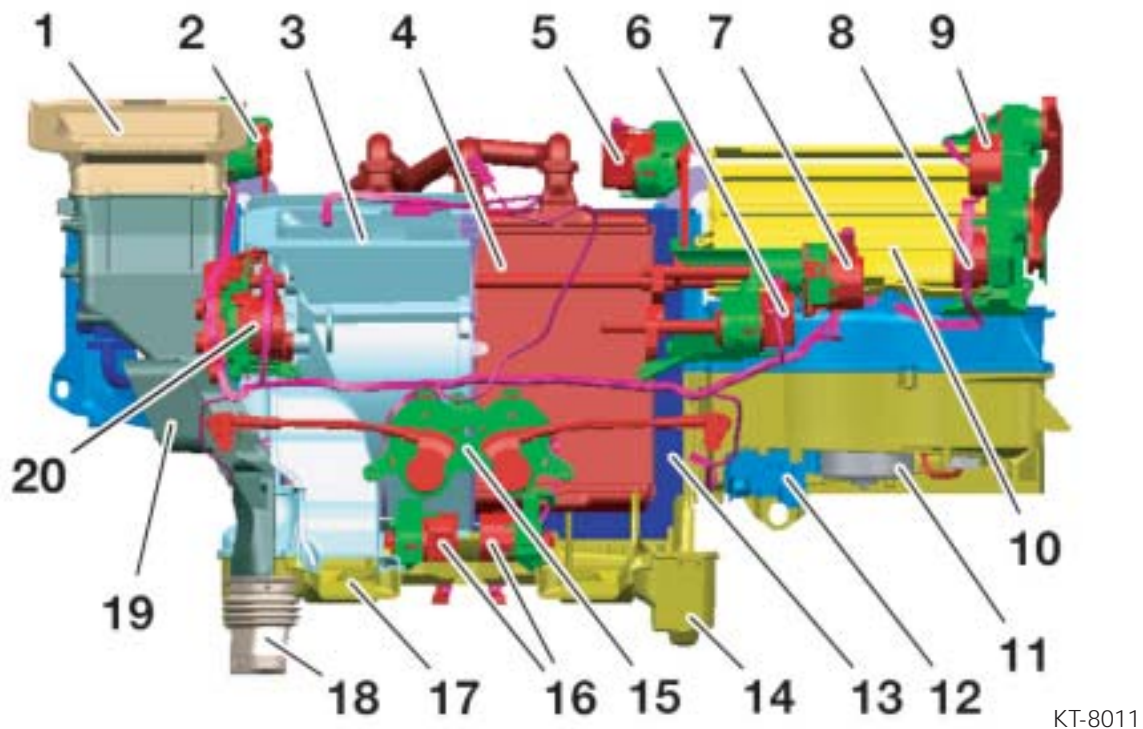

Layout of the IHKA major components (as viewed from the back)

- |                            |  |
|----------------------------|--|
| 1. Defroster duct          | 11. Blower motor                           |
| 2. Drive, warm air left    | 12. Blower control module                  |
| 3. Ventilation, left       | 13. Evaporator                             |
| 4. Heating exchanger       | 14. Condensation drain                     |
| 5. Drive, defroster        | 15. Drive, footwell                        |
| 6. Drive, cold air right   | 16. Drive, rear compartment ventilation    |
| 7. Drive, warm air right   | 17. Rear seat area duct, left, ventilation |
| 8. Drive, recirculated air | 18. Footwell/rear seat area outlet, left   |
| 9. Drive, fresh air        | 19. Footwell outlet, front left            |
| 10. Recirculated air flap  | 20. Drive, cold air left                   |

**Control Panel/Control Module:** The control panel is a dashboard insert with integrated electronic controls. The electronic circuits monitor and control the entire IHKA system. The control panel provides the essential basic controls. Precision adjustments are made using the Controller and the Control Display menu settings.

*IHKA control panel front view*



KT-8009

There are also controls for the hazard warning lights and central locking (Centerlock) functions (not part of IHKA system, only for location convenience).

### Functional Overview:

- DME (ECM) - Digital motor electronics
- PT-CAN - Bus cable
- K-CAN - Bus cable
- ZGM - Central gateway module
- MMI - control display
- TM - Door module
- SH ZH - auxiliary heating
- IHKA - E66 rear air conditioner
- PM - power module
- CAS - car access system
- ECU - IHKA control module
- LSZ - light switch center
- M PWR - stepper motors
- HR - rear window roller blind
- I/Os - inputs/outputs
- S-Sen - solar sensor
- AUCI/II-Sen - AUC I and AUC II sensors
- B-Sen - fogging sensors (future)
- S1 - limit position switch
- Poti - adjusting potentiometer

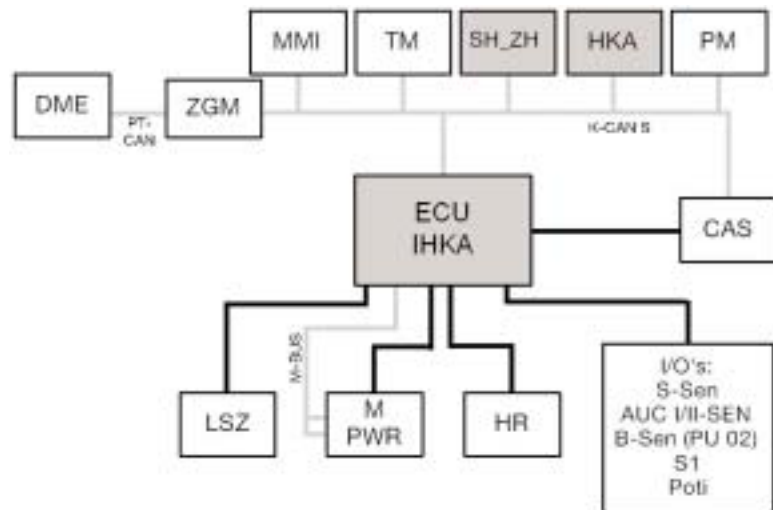

KT-8202



---

**Additional Sensors and Actuating Components:** The system includes other components in addition to those previously listed.

- AUC-2 sensor for automatic recirculated air control
- One solar sensor for each side
- One temperature sensor on each side in the center vent outlets
- One potentiometer on each side in the rear center outlets (for adjusting air stratification)
- One limit position switch on each side in the rear compartment center outlets

**AUC-2 Sensor:** The AUC-2 sensor provides an input to the IHKA module that will automatically activate recirculation mode when excessive ambient pollution is detected. This sensor detects pollutant gases emitted by gasoline and diesel engines that include the following:

- Hydrocarbons
- Carbon monoxide
- Nitrogen oxides

The heating and electronic analyzer (and software) are integrated into the sensor (located on the fan shroud). The sensor signal is pulse width modulated (PWM) to the IHKA control module.

The sensor is self diagnosable. Within the first minute of operation it determines if there is a fault in the sensor electronics. A fault will be set in the IHKA control module when a fault is detected.



KT-8038

**Solar Sensor:** The solar sensor is mounted on the dashboard top center grille. The black cap is visible which masks the diffuser and two (left and right) photo resistors. The cap only allows infrared light to pass through.

The solar sensor supplies the control module with a separate signal for left and right. These signal levels depend on the intensity of the sunlight striking the sensor. The solar sensor influences:

- Blower output
- Opening angle of the ventilation flaps
- Air stratification temperature



KT-8037

**Temperature Sensors:** The various temperature readings used by the IHKA control module are supplied from the following sensors:

***In the Heater and Air Conditioner Housing***

- Evaporator temperature sensor
- Two heat exchanger temperature sensors

***In the Control Panel***

- Interior temperature sensor with blower

***On the Vehicle***

- Exterior temperature sensor (signal provided over the K-CAN bus)
- Center air outlet grill of the dashboard (one temperature sensor for each side, 1 right)

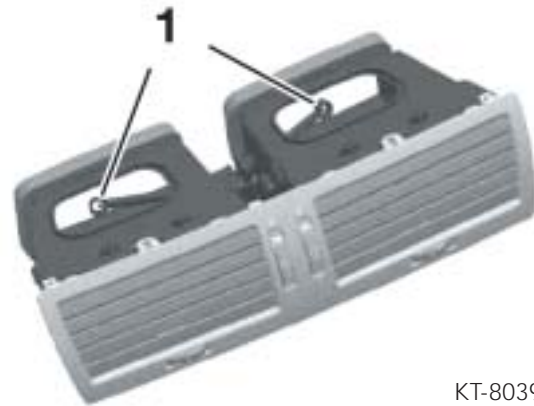

KT-8039

Each temperature sensor consists of a Negative Temperature Coefficient (NTC) unit in a plastic housing with injection molded connectors. The IHKA control module interprets the varying analog voltage signals as changing temperature. The NTC units used for evaporator and heat exchanger have different resistances, so the holders are mechanically coded to ensure that the sensors cannot be installed in the wrong location.

**Microfilter System (Air Intake):** There is a microfilter in each of the two air intake filter housings. The microfilters are a combination of particle filter and activated charcoal filter. The activated charcoal filters out unhealthy and noxious gases from the intake air before it enters the heater and air conditioner housing.

The service life of the filter depends on the degree of air pollution in the operating environment. The automatic recirculated air control function (AUC) with the filtration system provides optimum protection for the occupants of the car. The AUC function also prolongs the service life of the filter.

1. Inducted particles and gases
2. Particle filter (prefilter)
3. Micro-fiber matting
4. Carrier material
5. Activated charcoal filter
6. Covering layers, activated charcoal

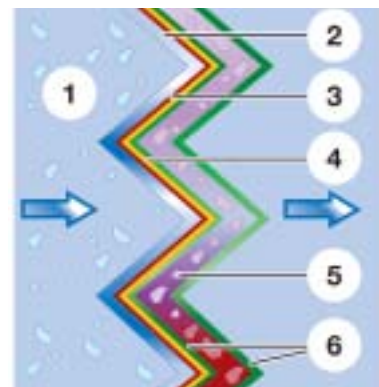

KT-8201

# Air Conditioning System

## System Components

**Refrigerant Compressor (KMV):** The refrigerant compressor compresses the refrigerant gas inducted from the evaporator and forces it to the condenser. The compressor does not have a clutch and it always operates when the engine is running. The compressor output is variable and is controlled internally by signals from the IHKA control module.

Delivery rate and pressure is produced by seven pistons. The piston stroke is influenced by a swash plate.

1. Solenoid valve
2. Hollow piston (Teflon coated)
3. Swash plate (MoS2 coated)
4. Belt pulley
5. Rubber elements

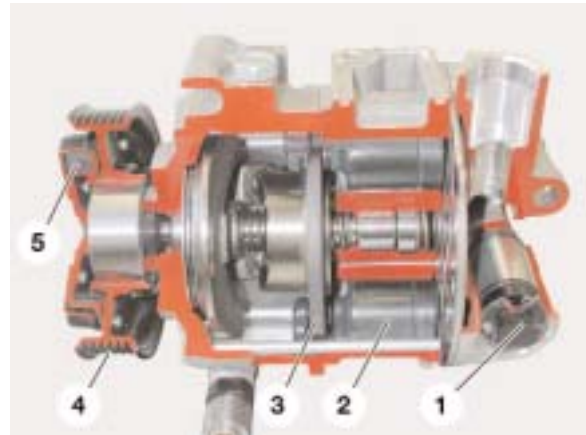

KT-8339

### Clutchless Drive Advantages:

- Compact
- Saves Weight
- No electric power consumption

### Application and Function:

- Vibration damping function
- Torque transmission
- Protective function in the event of a blockage

The illustration (right) shows the design of the refrigerant compressor drive with rubber elements.

1. Splines in the drive hub
2. Drive hub contour
3. Splined shaft
4. Rubber elements
5. Belt pulley

The rubber elements mesh with drive hub contour and will deform to give way (slip) if the compressor seizes.

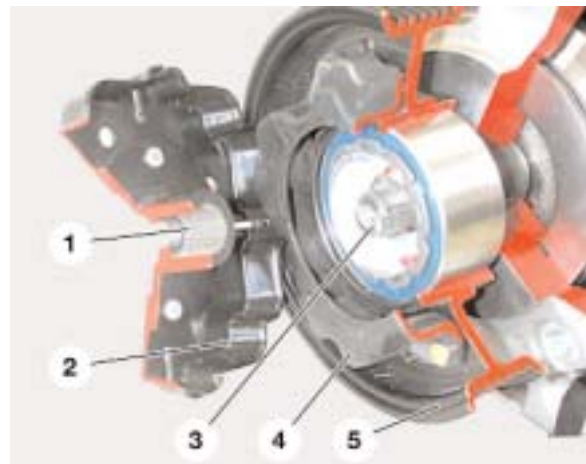

KT-8338

The position of the swash plate is varied by the internal pressure which is controlled by the electric control valve integrated into the compressor. The control valve influences the force at the swash plate by changing the crankcase chamber pressure (PC). When de-energized (control valve open), the swash plate is almost vertical and not deflected. The compressor output is approximately 0 - 2% which is required to maintain internal lubrication.

The IHKA control module sends a pulse width modulated signal (12V, 0.85A at 400 Hz) to close the control valve. This causes the pressure in the crankcase chamber to diminish. The swash plate is deflected (angled) and the compressor output increases (variable between 2 - 100%).

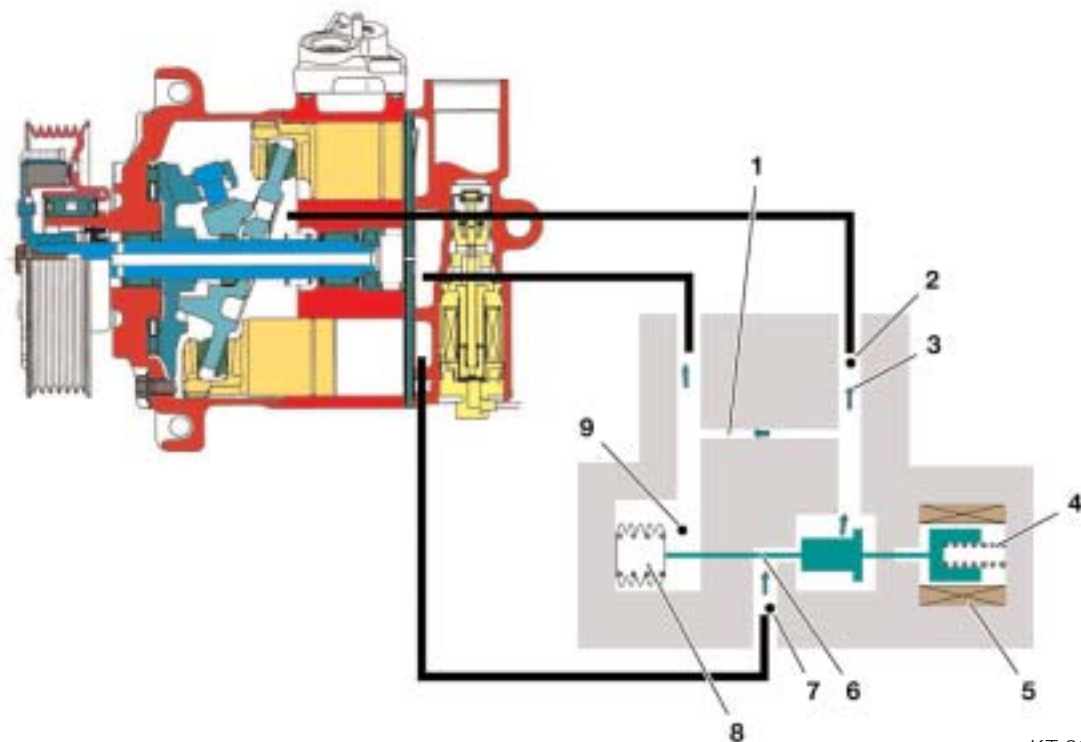

KT-8279

- |  |                          |
|--|--------------------------|
| 1. Orifice between crank case chamber pressure $P_c$ and intake pressure $P_s$ | 5. Coil                  |
| 2. Crankcase chamber pressure $P_c$  | 6. Valve tappet          |
| 3. Gas flow  | 7. High pressure $P_d$   |
| 4. Spring 2  | 8. Bellows with spring 1 |
|  | 9. Intake pressure $P_s$ |

**Condenser with Dryer:** Compressing the refrigerant gas in the compressor causes the temperature to rise. This heat energy is dissipated to the environment by air cooling the surface of the condenser. which causes the refrigerant to condenses and become liquid.

Any moisture that might be present in the system is trapped in the integral dryer to avoid corrosion damage in the refrigerant system.

The dryer insert (1) is replaceable. The granulated desiccant can absorb up to a maximum of 8 grams of water.

It is important to keep the refrigerant system sealed for as long as possible when performing repairs.

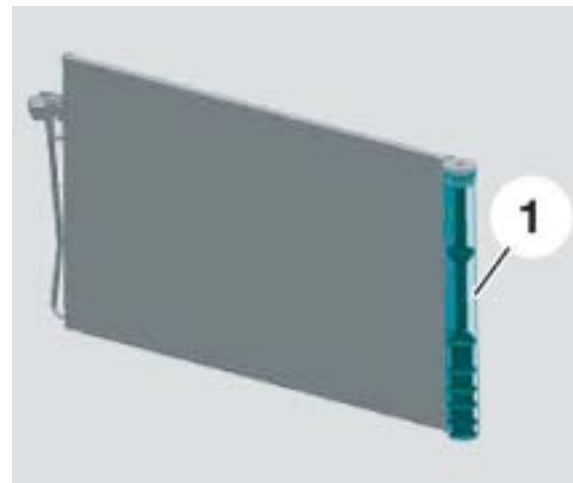

KT-8204

**Auxiliary Fan (ZL):** The auxiliary fan (approx. 420 mm diameter) has 5 asymmetrically rearward curved blades. The motor is the brushless type with electronic commutation (no brushes to wear). The fan speed is variable from 30 to 100%. The required fan speed is requested by the IHKA to the ECM over the CAN bus.

The ECM sends a PWM control signal to the fan motor final stage (integrated into the fan housing). At lower speeds and standstill (engine idling) cooling is assisted and maintained by the auxiliary fan.

The auxiliary fan is deactivated at vehicle speeds > 80 km/h (fan stage 0 is output). At higher vehicle speeds, ram air is sufficient to cool the condenser. The auxiliary fan is activated when the vehicle speed drops below 70 km/h. The operating stage depends on the refrigerant pressure. There are 15 possible speeds depending on refrigerant system pressures.

**Pressure Sensor:** The pressure sensor is in the pressure line between condenser and the evaporator.

The sensor sends the IHKA control module an analog signal between 0.4V and 4.6V as a representation of system pressure.

The 5V supply is provided by the IHKA control module and the sensor current consumption is < 20 mA.



KT-8205

**Expansion Valve:** The block type expansion valve in the E65 functions the same as models currently in use. The expansion valve is mounted directly on the evaporator in the air conditioner housing (accessible from the driver's side) and controls the inlet rate of liquefied refrigerant into the evaporator.

This ensures that the evaporator receives only as much liquefied refrigerant as it can evaporate (supply side = liquid/blue, outlet side = gas/red).

1. From evaporator
2. To evaporator
3. From condenser
4. To refrigerant compressor

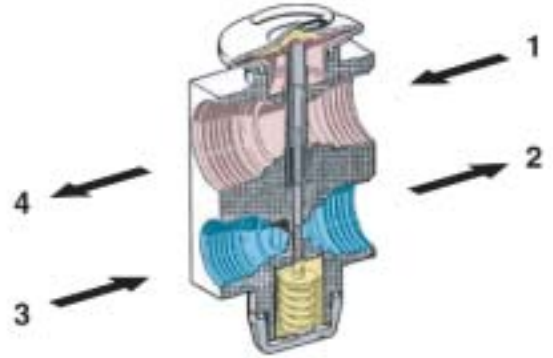

KT-8207

**Evaporator:** The evaporator is an aluminum plate type surface that consists of 27 plates with a total surface area of approximately 5 square meters. To avoid corrosion, the evaporator has a very thin coating to speed condensation drain off.

Cooling the air causes some of the contained moisture (humidity) to condense, so the evaporator control is set not to drop below approximately 2 °C in order to prevent ice from forming. The temperature is monitored by the evaporator temperature sensor.



KT-8212

**Notes:**

---

---

---

---

---

---

---

---

---

---

---

## Principle of Operation

### Evaporator Temperature Control and Refrigerant Circuit Monitoring

The evaporator temperature control keeps the evaporator temperature at a constant 2 °C and operates independently of the other control circuits. The variable output to the refrigerant compressor is derived from or limited by the following criteria:

- Difference between requested setting and actual value of the evaporator temperature
- Compressor speed
- Coolant temperature
- Compressor load torque
- Torque limitation
- Refrigerant pressure limitation
- Kick down (vehicle acceleration)
- Battery voltage

### Requested Setting and Actual Evaporator Temperature Difference

The cold air exiting from the evaporator is reheated to the desired temperature by the heat exchanger. To control ventilation, the measured evaporator temperature is used as an influencing variable to compute the angle of the cold air flap.

### Refrigerant Compressor

The compressor is activated on demand when all switch on criteria is met. It is an internally regulated and externally controlled compressor. The control valve is manipulated by a variable PWM (400 Hz) signal to ensure that only the refrigeration required at a given time is generated by the compressor. This reduces the load when full cooling power is not needed.

### Compressor Speed

K-CAN messages provide the IHKA with engine speed information (from the ECM) which represents compressor speed.

---

## **Compressor Load Torque**

The variable load torque is derived from the evaporator temperatures (requested setting and actual) by the IHKA to generate the PWM signal for the solenoid valve to deflect the swash plate. The physical compressor load torque requirement is calculated by the IHKA control module and sent to the ECM over the K-CAN Bus.

## **Torque Limitation**

The IHKA receives a K-CAN message from the ECM containing a maximum specified torque. Under full throttle/kick down and at high coolant temperatures, the ECM uses this signal to restrict the maximum possible compressor load torque.

## **Refrigerant Pressure Limitation**

The refrigerant pressure is monitored through the pressure sensor to avoid excessive system high side pressures. The IHKA limits refrigerating power linearly from 100% to 0% (shutdown) between 22 to 28 bar of pressure.

The compressor is deactivated when the pressure is  $< 1.8$  bar. The compressor is reactivated when the pressure is  $> 2$  bar, provided that all the other switch on criteria is met.

## **Compressor - Running In**

When the compressor is operated for the first time it must be run in to ensure proper lubrication (oil distribution). During the Running In procedure the compressor must be operated at speeds between 300 to 1200 rpm.

If the speed drops below 300 rpm or rises above 1200 rpm during the Running In phase, it is interrupted and automatically resumed after a delay of 5 seconds (refer to Service Functions).

## **Communication between IHKA and the ECM**

The IHKA notifies the ECM of the request for compressor activation in a K-CAN message (Control A/C ready).



---

In anticipation of the compressor load and based on the outside temperature, this is accomplished by increasing engine idle speed from 550 to 750 rpm.

There are three different switching criteria:

- 0 = No air conditioning required, system ON
- 1 = Air conditioning required, system ON without speed increase
- 2 = Air conditioning required, system ON with speed increase

The ECM provides the IHKA with a torque of 30 Nm, provided that deactivation criteria does not apply (high coolant temperature, kick-down, etc.). The IHKA will activate the refrigerant compressor in the permitted torque range and reports the actual torque applied back to the ECM.

### **Limitation of Compressor activation by the ECM**

The ECM sends a K-CAN message notifying the IHKA of the maximum available torque. If this maximum available torque is less than the current compressor load torque, the valve signal is reduced until the load of the compressor drops to or below this value. If this can not be accomplished by the minimum valve signal, the compressor is shut down.

## **Workshop Hints**

### **Initial Operation after Replacing the Refrigerant Compressor**

*When the compressor is operated for the first time (after replacement) it must be run in to ensure proper lubrication (oil distribution)!*

Procedure:

1. Set all air vents in the instrument panel to "OPEN".
2. Start the engine and wait until it stabilizes at a constant idle speed.
3. Set the speed blower to at least 75% of the maximum output.
4. Switch on the A/C system and allow it to operate for at least ***2 minutes at idle speed (risk of damage at higher speed)***.

**Note:** The engine speed must not exceed 1200 rpm. If it does, the procedure will automatically abort and must be repeated.

Consult the Repair Information (in TIS) for the correct compressor oil filling procedure and the Running In phase that allows thorough and uniform mixing with the refrigerant.

## Heating System

### System Components

**Auxiliary Water Pump (ZWP):** The ZWP is a rotary pump with an electronically commutated direct current motor. The pump housing is sealed from the motor. Drive from the motor is transmitted to the impeller through the sealing partition.

The ZWP is protected against blockage and reverse polarity. In the event of a thermal overload, power is reduced down to intermittent operation.

The ZWP enhances hot water flow (1 - outlet, 2 - inlet) and ensures the minimum flow rate, particularly when the engine is idling or off (residual heat function).



**Dual Water Valve (WV):** The dual water valve operates electromagnetically to meter the volume of coolant flow to the left and right heat exchangers.

This function is performed by an open/close ratio that the IHKA control module varies according to the demand. The valves are sprung open when de-energized.

1. Left heat exchanger circuit
2. Hot coolant inlet
3. Right heat exchanger circuit



**Heat Exchanger (WT):** The aluminum heat exchanger is the flat tube type consisting of two halves (left and right) with one inlet for each and a common outlet. It transfers the thermal energy supplied by the flow of heated coolant to the air flowing through.

Under ideal conditions as much as 10 kW of heating power can be produced.

There are two heat-exchanger temperature sensors located in the air stream (left/right) that measure the exiting air temperature.



# IHKA Heater and Air Conditioner Housing

## System Components

The Heater and Air Conditioner Housing consists of the following components/functional units:

- Evaporator/evaporator sensor
- Heat exchanger/sensor
- Blower
- Blower speed control module
- Flaps/flap actuating mechanism
- Flap drives/stepper motors

### Flap Drives:

1. Warm air left
2. Defrost
3. Fresh air
4. Recirculated air
5. Warm air right
6. Cold air right
7. Footwell right
8. Rear seating area right
9. Rear seating area left
10. Footwell left
11. Cold air left

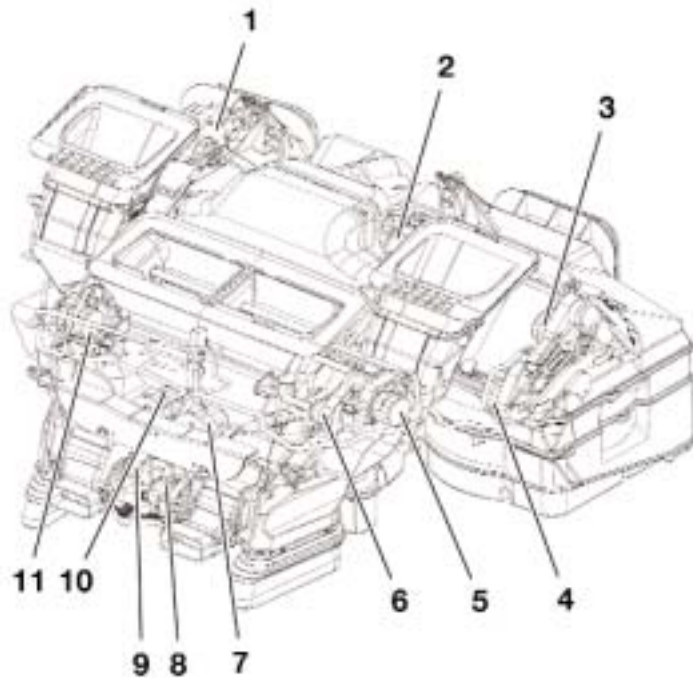

KT-8376

**Blower:** The blower assembly is a radial flow blower with a fan impeller on one side. It is mounted with the blower motor in a sound proofed housing (1), offset to the passenger's side. The blower control module can be separated from the motor.

The blower produces the required air mass flow and under ideal conditions can achieve a maximum flow rate of approximately 9 kg/min.

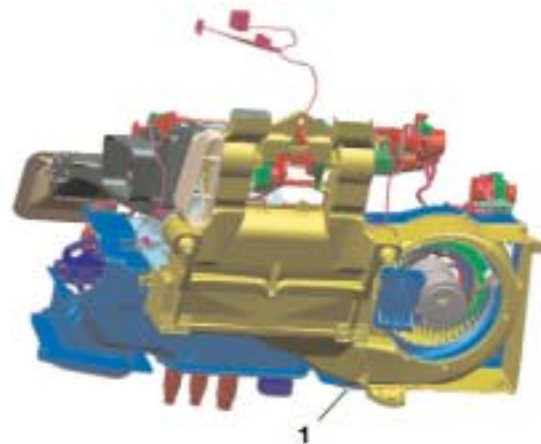

KT-8346

Depending on the positions of the air flow control flaps, the required quantity of air is inducted either through the fresh air filters or through the recirculated air flap depending on the operating status.

Technical data of the blower motor:

Type	Permanent Direct current motor
Voltage	12 V
Rated speed	3350 rpm
Rated current consumption	27 A

**Blower Control Module:** The blower control module is mounted directly on the blower motor housing. It has self diagnosis capabilities and is addressed by the IHKA control module over the K-bus (view from below inside open IHKA housing).

1. Blower control module
2. Blower



KT-8208

The blower control module uses a “clocked” regulator which reduces control power losses. This significantly saves energy and requires a smaller heat sink.

The diagnostic information is transmitted to the IHKA control module for processing. If a fault is detected in the regulator or blower that would cause an overload (overheat), current is reduced or the blower is temporarily shut down.



KT-8209

**Flaps/Flap Actuating Mechanism:** The flaps distribute the air and mix cold air with warm air. The flap actuating mechanism includes the flaps, corresponding shafts with lever assemblies and the drive motors.

The flaps in the IHKA are as follows:

**Fresh Air Flap:** This flap regulates the quantity of fresh air inducted by the blower. It is actuated by a rapid action drive to close quickly when the system is operating in automatic recirculation air mode (AUC mode). This flap also acts as a dynamic pressure compensator.

**Recirculation Air Flap:** This flap is a three vane louver (1).

The recirculation air flap regulates the volume of recirculated air inducted into the system.

The recirculating air filter is located directly above it.

**Footwell Flap:** These flaps (separate for left and right) control the flow of air to the front and rear footwells.



KT-8347

**Rear Seating Area Ventilation Flap:** These flaps regulate the volume of air flow and the temperature (air stratification) from the rear ventilation outlets (separate flaps for left and right).

**Defrosting Flaps:** These two flaps are coupled together to regulate the air flow against the windshield. In all adjustment and control functions, these two flaps are controlled from the driver's side only.

**Warm Air/Cold Air Flap:** These flaps control the air flow/temperature stratification to the outlets in the dashboard and B pillars (separate flaps for left and right). Each pair of flaps (warm air/cold air) regulate the air flow and the temperature at the same time.

**Flap Drives/Stepper Motors:** All flap drives are designed basically the same, including the following components:

- Stepper motor
- Plug housing
- Reduction gearing

The external distinguishing features are the different types of levers and rods and the physical configuration (alignment) of the connectors. The drives are decoupled by clips.



KT-8297

IHKA has a total of 11 stepper motors:

- 1 Rapid action motor for the fresh air flap
- 10 Stepper motors for all other flaps



## Control Panel/Control Module

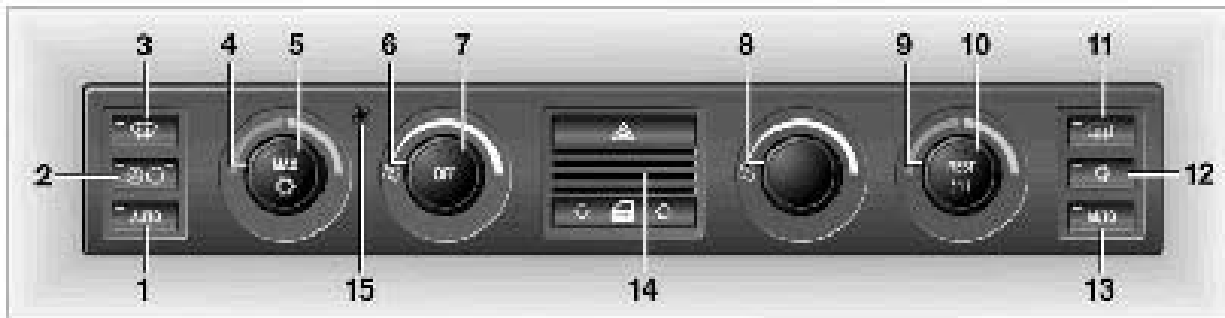

KT-8297

The IHKA detailed controls are:

1. AUTO left button (LED: green)
2. Recirculated air/AUC button (LED: both green)
3. DEFROST button (LED: orange)
4. TEMPERATURE left knob
5. MAX AC button (LED: green)
6. AIR VOLUME left knob
7. System OFF button (LED: orange when system is switched off)
8. AIR VOLUME right knob
9. TEMPERATURE right knob
10. REST button - residual heat mode (LED: green)
11. Rear window defroster button (LED: orange)
12. Air Conditioner button (LED: green)
13. AUTO right button (LED: green)
14. Air grill for interior temperature sensor
15. Parked-car ventilation system indicator (flashing when activated)

---

## Function Operations Based on Ignition Switch Positions

### Terminal 30 (Ignition OFF)

- Residual heat (Rest function)
- Parked-car ventilation

### Terminal R (Accessory Position)

- Residual heat (Rest function)
- Parked-car ventilation
- AUTO (residual heat/parked-car ventilation)
- OFF (residual heat/parked-car ventilation are deactivated when "OFF" is selected)

### Terminal 15

- Parked-car ventilation
- AUTO Driver
- AUTO Front passenger
- AC
- DEFROST
- MAX AC
- Recirculating air
- AUC
- HHS (rear window defroster)
- OFF

## Communication Between IHKA and Control Display

The following messages are interchanged between the IHKA and the Control Display over the K-CAN bus:

From IHKA to Control Display:

- Status of air conditioner, front
- Status of air distribution, driver's side
- Status of air distribution, passenger's side

From Control Display to IHKA:

- Operation of air conditioner, front
- Operation of air distribution, driver's side
- Operation of air distribution, passenger's side

## Functions of Other Buttons on the Control Panel

**CENTERLOCK:** The status of the CENTERLOCK button is looped through the IHKA to the appropriate control module.

**HAZARD WARNING LIGHTS:** The status of the HAZARD WARNING LIGHTS button is looped through the IHKA to the appropriate control module. The hazard warning lights indicator LED is activated by the lights switching center.

## Connected Loads

The power requirement of the control module is 16 Amp (max.).





- M1 to M10 - Flap drives (stepper motors)
- BEL AB - Ventilation for storage box (future)
- WHZG - Wiper parked zone heating
- M11 - Fresh air flap
- PM - Power module
- WTFL - Heat exchanger temperature sensor, left
- KMV - Refrigerant compressor
- WTFR - Heat exchanger temperature sensor, right
- HSR - Rear window roller blind
- VDF - Evaporator temperature sensor
- KL30 - Terminal 30
- F2 - Fresh air grill, front
- GEB - Blower
- DSEN - Refrigerant pressure sensor
- CON - Controller
- AUC - Automatic recirculated air control
- BZM - Center armrest control console
- WV - Water valve
- CD - Control Display
- ZWP - Auxiliary water pump
- DME - (ECM) Digital engine electronics
- LM - Light module
- ZGM - Central gateway module
- WB - Hazard warning lights system
- SP - Blocking circuit
- CTL - Centerlock
- HHS - Rear window defroster
- CAS - Car Access System
- AT - Antenna tuner
- SSEN - Solar sensor
- PT-CAN - Powertrain bus
- F1 - Fresh air grill, rear seating
- K-CAN S - Body controller area network system
- BSEN - Fogging sensor (future)

## Functional Circuit Diagram

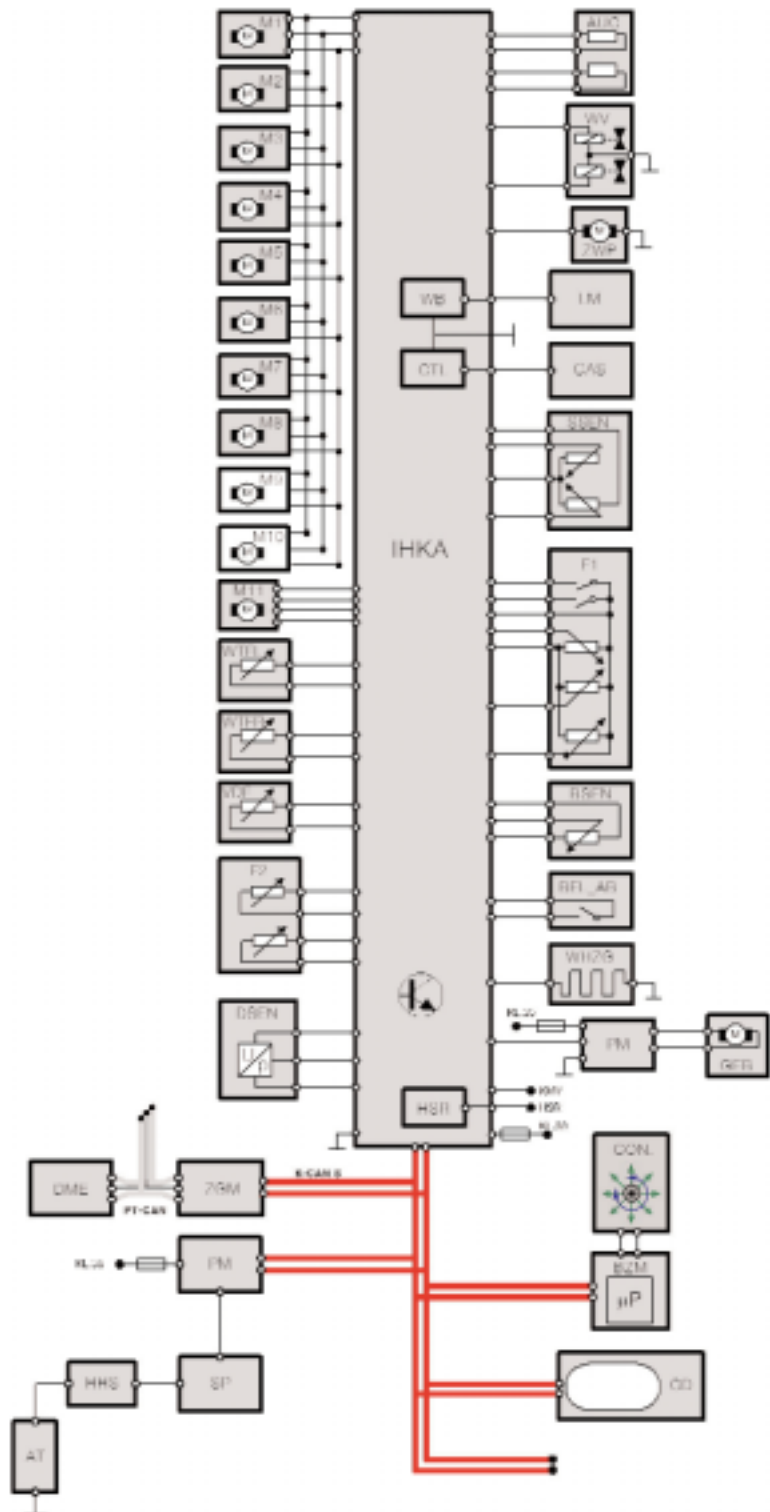

---

## Temperature and Air Flow Control

### Principle of Operation

#### Temperature Control

The basis of the temperature control system consists of the left and right master controllers (Y Factor). These controllers compare the interior temperature actual value with the occupant's requested temperature settings for left and right. The control obtains a differential signal, which it uses to generate the variable Y (factor).

The operating range of the master control is from - 200% to + 311.5% Y. A wide variety of functions in the IHKA are influenced by this, for example: the flap and automatic blower control. The subordinate systems include two auxiliary regulating circuits for the left and right heat exchangers to suppress the temperature fluctuations in air throughput or water flow.

Two other independent loops control the ventilation temperature for left and right, thus allowing stratification of the air temperature between the footwell outlets and the ventilation outlets.

#### Passenger Compartment Control (Master Controller)

The passenger compartment controller is proportional (linear). The temperature range that the vehicle's occupants can select is from approx. 61° F to 90° F (16° C to 32° C).

The step interval is:

- Temperature °F in increments of 1.0 ° F
- Temperature °C in increments of 0.5 °C

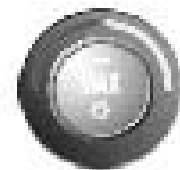

42-14-11

#### MAX Heating Function

When the setpoint is 32° C, MAX heating is activated for left and/or right individually. The interior temperature controller is overridden. The temperature of the heat exchanger is brought up to the maximum of 90 °C. The variable Y is set to maximum heating (true 311.5%).

**Exception:** The water valves will remain closed in the parked-car ventilation mode, so the MAX heating function is cancelled.

---

## MAX Cooling Function

When the setpoint is 61° F, MAX cooling is activated for left and/or right individually. The interior temperature controller is overridden. The heat exchanger temperature is reduced to the minimum of 5 °C and the water valve(s) is closed. The variable Y is set to -200% (maximum cooling) and the recirculation mode automatically takes place.



42-14-11

## Correction for Setpoints

**Outside Temperature Influence:** The outside temperature is registered by a sensor at the bumper and is sent to the IHKA over the K-CAN bus. The setpoint is corrected to compensate for the effects on the vehicle's occupants from radiant heat. The outside temperature influence and the associated setpoint increase can be between +12 to -2 °C.

**Interior Temperature Sensor:** The temperature sensor measures the temperature inside the passenger compartment. This temperature sensor furnishes the most important, the sensor value is monitored and processed at a very high resolution (0.1667 °C).

## Heat Exchanger Control

The temperature of the heat exchangers is monitored by temperature sensors situated directly in the discharge air flow (left and right). The heat exchanger setpoint is calculated on the basis of the master controller's variable Y to correct fluctuations in heat exchanger temperature.

**Exception:** If the variable Y factor is < 0%, the water valve of the heat exchanger(s) is closed.

## Heat Exchanger Characteristic Map

The duration of water valve(s) opening compensates temperature control based on a speed dependent heat exchanger characteristic map for various engine speeds.

Pulse width modulation from the IHKA controls the water valves to open longer for lower engine rpm and open shorter for higher rpm.

---

## Filling Station Effect

The filling station effect occurs when the valves are de-energized (sprung open), allowing the heat exchanger to fill with hot coolant. This is avoided by maintaining the power supply to the water valves for 3 minutes after KL15 is switched "OFF".

## Engine Characteristic-Map Cooling

To avoid damage to the heater and air conditioner, the heat exchanger temperature is limited to a maximum of 90 °C. If a defective water valve causes the temperature in the heat exchanger to rise too high (> 98 °C), a K-CAN message is sent to activate the Characteristic-Map cooling in the ECM.

## Auxiliary Water Pump

The electric auxiliary water pump ensures that the requested water flow rate is maintained even at low engine speeds.

**ON:** Residual Heat Function

*or*

KL15 ON *and*

Engine temperature > 0 °C *and*

Blower not on zero setting *and*

Variable Y (driver or passenger) > 5%

*or*

DEFROST

*or*

MAX heating

**OFF:** Residual heat function not active *and*

KL15 OFF

*or*

Engine temperature < 0 °C

*or*

Blower setting on zero

*or*

Variable Y (driver or passenger) < 0% *and*

DEFROST not active *and*

MAX heating not set

---

## Face Vent Outlet Stratification

To achieve the air temperature and air flow rate, output is calculated taking the following variables into account:

- Temperature setting selected by the occupants (variable Y)
- Air stratification setting using the Controller in the Control Display settings menu
- Ventilation temperature (actual value)
- Solar sensor
- Outside temperature
- Flap characteristics for the footwell
- DEFROST ON/OFF
- Correction factors
- Temperatures of evaporator and heat exchanger

Once the face vent outlet stratification is set, characteristics are applied to correct the positions of the cold air and warm air flaps (air mix) to achieve the desired flow rate and temperature at the ventilation outlet.

The proportions of the warm and cold air flow determines the ventilation temperature. This affects the temperature and the air flow rate in the entire system each time the angle of a flaps is changed.

1. Face vent outlet duct
2. Air flow to ventilation (ventilation temperature)
3. Cold air flap position
4. Cold air flow (evaporator temperature)
5. Warm air flow (heat exchanger temperature)
6. Warm air flap position

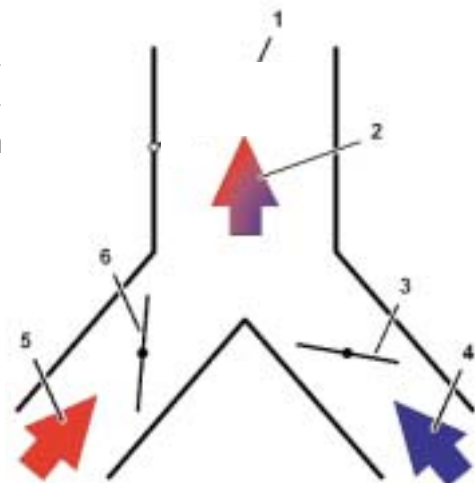

KT-7792

## Ventilation Control (Stratification) Front

The inputs used to generate the setting for the face vent temperature are:

- Temperature variable (Y)
- Stratification using the Controller in the Control Display settings menu
- Solar sensor value
- Outside temperature

---

The setpoint calculation for the ventilation temperature is based on the heat exchanger and evaporator temperatures. The calculation provides the approximated flap angles to produce the ventilation temperature.

There are ventilation sensors (left and right) to monitor the ventilation temperature. These sensors allow the IHKA to monitor the true ventilation temperature which is compared to the requested ventilation temperature. The IHKA will “fine tune” the flaps to decrease the difference.

The angle of the footwell flap is taken into account as a factor for the volume of air that is lost when the footwell flap is open. The variable (Y) function is added to force the warm air flap open in cooling mode (heat exchanger cold) to increase the air volume flow.

1. Evaporator
2. Heat exchanger
3. Warm air flap
4. Cold air flap
5. Flap for rear seating ventilation  
(warm air, cold air and shut off)

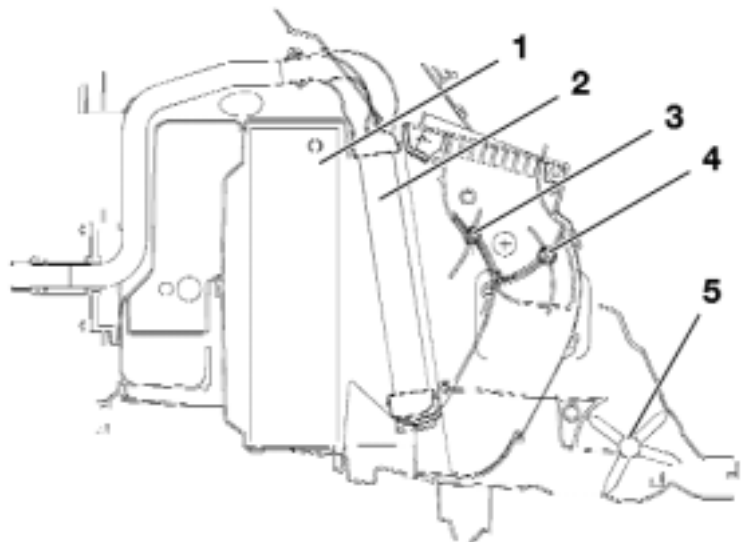

KT-8345

### Ventilation Control (stratification) Rear

The air stratification flaps for the rear of the passenger compartment (left/right are separate) discharge perform two functions:

- Shut off the flow of air to the vents (shut off flaps at the vents are closed manually)
- Control the discharge temperature by mixing warm air and cold air (flap 5 above)

The limit position switches at the shut off flaps of the center vent will signal a request to the IHKA to closed or open the supply flap (flap 5 above).

## Air Flow Control

### Automatic Blower and Flap Control



42-14-06

When the "AUTO" button (left or right) is pressed or a request is made by using the Control Display, the automatic blower and flap control is activated (depends on variable Y) and the "AUTO" LED is illuminated. When the blower control knob is turned, automatic blower control (for that) side is deactivated. Automatic flap control remains active. Pressing the "AUTO" button again reactivates automatic blower control. The current blower output is displayed on the Control Display in manual mode only.

### Dynamic Pressure Compensation

As vehicle speed increases, the increase in "ram air" is controlled by Dynamic Pressure Compensation to maintain consistent air flow volume. The ram air is compensated by closing down the fresh air flap to restrict the air intake duct in response to the road speed signal (over K-CAN). To prevent the flap position from being changed continuously in response to minor changes in road speed (overcompensation), buffering is included in the calculation for the desired flap position. In the 80 to 180 km/h speed range, the fresh air flap angle is reduced from 100% to 30%.



42-14-09

### Manual Blower Adjustment

Turning the control knob(s) clockwise increases blower output and counter clockwise decrease output. The knobs do not have limit stops and detente in stages from 1 - 14 (power is increased or decreased one level for each click). Blower output is visualized in the bar indicator in the Control Display.

Once the maximum or minimum setting is reached, turning the potentiometer further in the same direction has no additional effect and output remains at the MAX or MIN setting. The new blower value is immediately transmitted to the Control Display.

- A. Manual blower setting
- B. Blower output
- C. Potentiometer detent position
- D. Blower stage

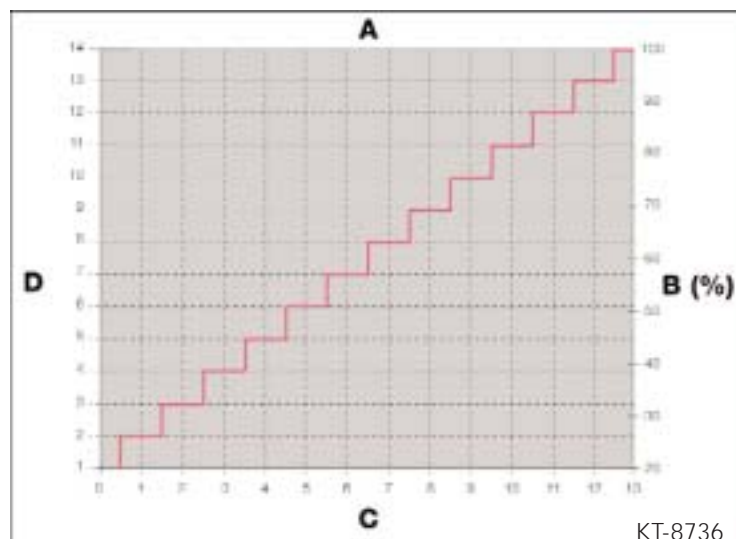

KT-8736



## Automatic Blower Boost

Automatic blower boost is available when the flaps are adjusted manually or automatically.

- A. - Blower output
- Y. - FA variable, driver's side

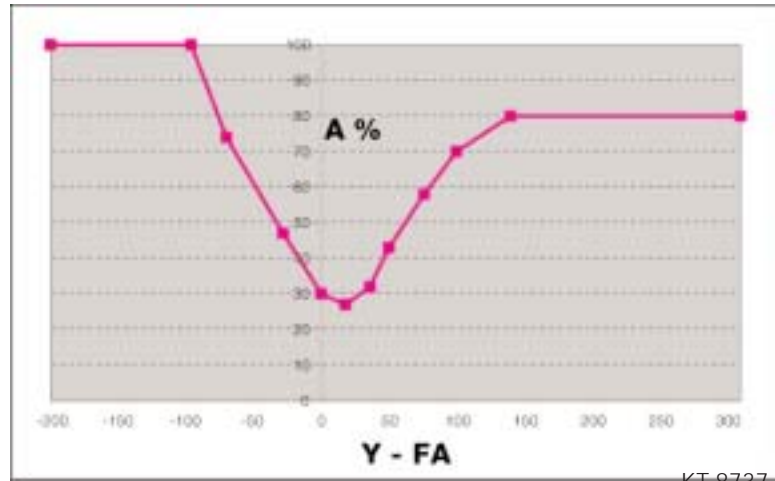

To expedite cooling or heating to counter extreme cabin temperatures, the normal range of adjustment (Y) is increased to - 200% ... 310%. Automatic blower control only responds to the driver's side value.

## Limitation in Cold and Warm Ranges

When the variable (Y) > 10%, maximum blower output is limited as a function of coolant temperature.

This avoids unwanted cold air drafts until warm air can be produced.

- A. Limitation in cold/warm ranges
- B. Coolant temperature
- C. Maximum blower output

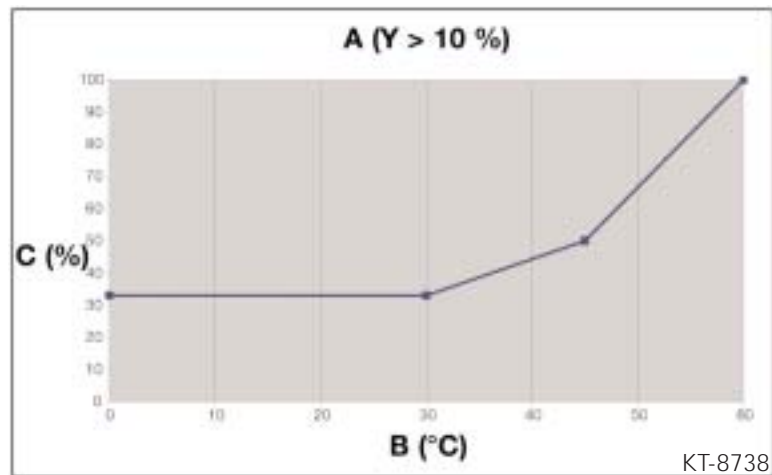

## Blower Control Function Based on Electricity Supply

When the power module triggers a consumer shutdown over the K-CAN bus, the following applies:

<u>Blower Output</u>	<u>Priority Level</u>
• OFF	1
• 50%	4
• 100%	> 4

**Note:** The reduction in blower output or shutdown for priority level 1 or 4 does not apply to the "DEFROST" function.

Blower voltage is reduced in the same ratio as the vehicle voltage from 12.0 V downward.

If the vehicle voltage drops 10% below 12.0 V, the blower control voltage and the blower voltage are also reduced by 10%.

- A. Vehicle voltage
- B. Blower reduction

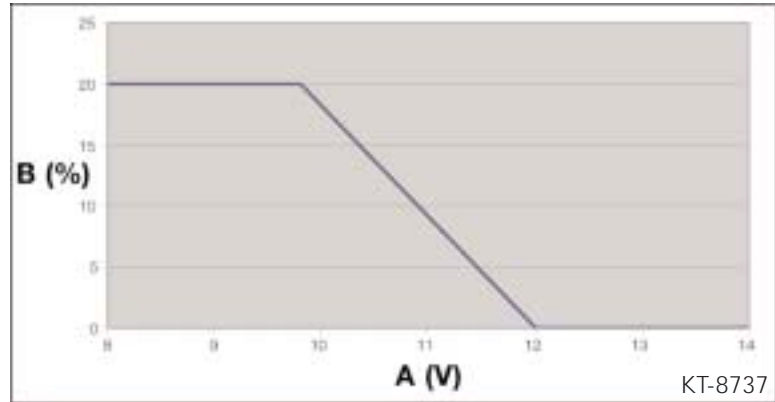

### Effect of Terminal 50 (Start Signal)

During engine starting, the battery is not subjected to the extra load by the blower current consumption. As long as "KL50 logically on" remains (starter motor), the blower control voltage is held at 0V (blower off).

**Fault Handling, Terminal 50:** A communication defect affecting the "terminal 50 logically on" bus message will shut down the blower and the duration of the active state (KL50) is monitored.

**The "Terminal 50 Logically On" Status is overridden When:**

- KL50 active for longer than 30 seconds
- Engine speed >500 rpm
- "Engine running" K-bus message is received

The original KL50 status is considered invalid, and although no fault message is in memory the function is "logically off". The blower circuit remains inactive until KL15 is switched "OFF". The blower circuit is reactivated by the next KL15 ignition "ON" status.

**Notes:**

---

---

---

---

---

## Air Distribution

### Principle of Operation

There are a number of ways to select the air distribution mode:

- Automatic program - selectable by the button on the control panel or the air conditioning menu on the Control Display.
- Prioritized programs - selectable by the buttons on the control panel.
- Manual air distribution programs - selectable by the air conditioning menu on the Control Display.
- INDIVIDUAL settings (no program) - selectable by the DUAL function in the air conditioning menu on the Control Display (future).

The air distribution status is always transmitted to the Control Display for the flap range from 0% (flap closed) to 100% (flap open).

### Flap Positions

The flaps are positioned according to the driver's side control setting (including Y). The LHD/RHD ID is needed for this purpose when coding. The flaps and positions that are activated (together) for both sides of the heater and air conditioner unit are: fresh air, recirculating air and Defrost.

### Flap Position Priorities

The initial position of each flap is defined in according to the following priorities:

- Calibrating run (after connection of the battery)
- Parked-car ventilation OR utilization of residual heat (Rest feature)
- Position run (when KL15 is switched OFF)
- DEFROST program
- MAX-AC program
- OFF mode (blower zero position)
- Cold starting interlock

---

If one of these functions is active, the nominal positions of the motors are used. If none of these functions are active, the nominal position is recalculated for each flap, taking into account the button selected (flap program).

## Calibration Run

The stepper motors do not have a "feedback" function to recognize the actual positions, they always move to a reference position. The reference position is the flap limit positions 0% or 100%.

The flaps always move to a limit position for each "power-on reset" (reconnect battery). This allows the IHKA to start from the reference to properly position the flaps during normal operation. A calibrating run can also be initiated by the DISplus.

## Overflow

When at the limit position (0% or 100%), the fresh air flap is subjected to an OVERRUN (precautionary measure). In OVERRUN, the stepper motor is sent "10 overrun steps" every 20 seconds. The fresh air motor is sent overrun steps in the CLOSED direction (so flap is sealed correctly) and in the OPEN direction (correction if the flap is frozen closed).

## Position Run

When the ignition (KL15) is switched "OFF", the fresh air/recirculated air flap is moved to the "fresh air position". This ensures the supply of outside air to the passenger compartment in the event of an IHKA failure.

## Manual (Individual) Air Distribution

Manual air distribution is controlled through the Control Display.

The IHKA provides separate individual air distribution settings to increase /decrease airflow for the driver's and passenger's side.



42-14-17

## Automatic Program

### Defrosting flaps

To avoid post start fogging, the defroster flap remains closed for 12 seconds after the engine is started, before operations return to normal. When the DEFROST function is cancelled, the defroster flap is moved to the new flap position (after a slight delay). When the AUTO button on the driver's side is pressed, the defroster flaps are opened or closed according to program variable (Y).

The AUTO button on the passenger's side does not effect the position of the defroster flaps.

- A. Variable Y
- B. Flap aperture

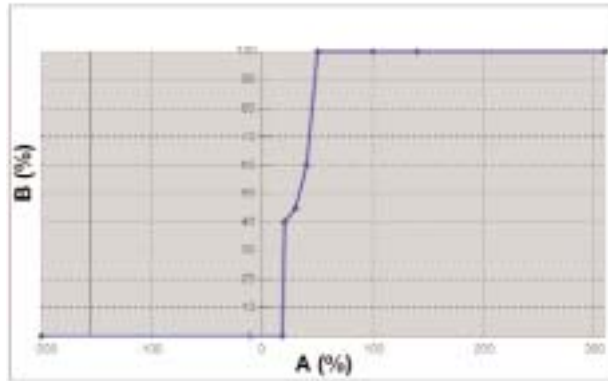

KT-8741

### Footwell Flaps

When the AUTO button on the driver's or passenger's side is pressed, the footwell flaps are opened or closed according the the variable (Y) program.

- A. Variable Y
- B. Flap angle

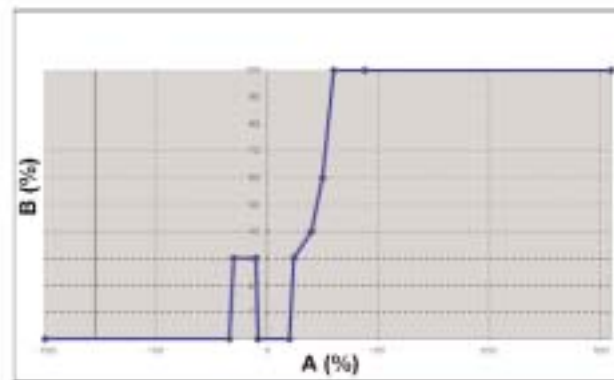

KT-8743

## Settings for the "INDIVIDUAL" Program

The flaps that can be set individually by the Control Display are:

### Driver's Side

- Defroster flap
- Virtual flap
- Footwell flap

### Passenger's Side

- Virtual flap
- Footwell flap

When the positions of the flaps on the left side are changed, the program set for the right side is deleted.

The individual settings allow the flaps on the left and right sides to be opened or closed separately in steps of 10%.

The correct flap positions are held and can be called up with the INDIVIDUAL program.



42-14-16

**Special Case:** When a special program is active (MAX-AC, DEFROST, etc.) the program selected beforehand is reselected initially if an individual air distribution setting is selected.

### Cold-Starting Interlock

Cold-starting interlock avoids unwanted cold air drafts until warm air can be produced and is activated with the following conditions:

- ON:** Variable (Y) DRIVER setting = 100% **and**
- AUTO program selected **and**
- Heat exchanger temp. driver's side < 30 °C

Cold-starting interlock is deactivated when any one of the three conditions is not met. The flap positions for cold-starting interlock depends on the outside temperature. If outside temperature is < 0 °C, the defroster flap is OPEN and the footwell flaps CLOSED. The opposite applies for outside temperatures > 0 °C.

### MAX-AC Function

The MAX-AC function enables the user to select the maximum cooling power by a single touch of a button on the control panel. The MAX-AC function has the highest priority after the DEFROST function.



42-14-11

All functions including DEFROST are deactivated when the MAX-AC button is pressed and the air conditioning function is switched on. The air conditioning function will remain active when the MAX-AC function is terminated.

The MAX-AC function is terminated when any button on the control panel is pressed or a change made to the settings on the Control Display. The newly selected function becomes active and the settings selected before the MAX-AC function are reactivated (except DEFROST). Pressing the MAX-AC button while the MAX-AC function is active also terminates the MAX-AC function.

### Special functions in conjunction with the MAX-AC function

- **Multi-function steering wheel (MFL) actuation:** When the MAX-AC function is active there is no reaction to the MFL controls.

## DEFROST Function

The DEFROST function is a priority function in air distribution. DEFROST is activated by pressing the DEF button. The DEFROST function is the highest priority function after the OFF function. When the DEFROST function is activated all the function LEDs go out, with the exception of the rear window heating LED is active (if selected). The blower can be adjusted while the DEFROST function is active.



42-14-08

### Additional Outside Temperature Influence for DEFROST

TA Outside temperature  
A Increase in Kelvin (K)

This adjustment is applied according to the following criteria:

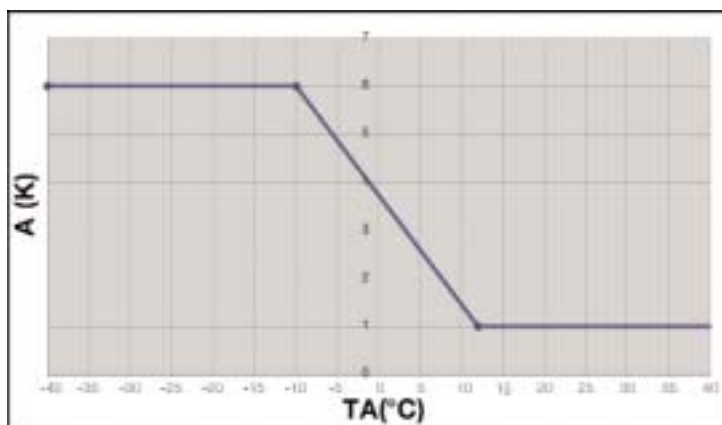

KT-8748

**Uncontrolled DEFROST function:** Outside temperature < -5 °C

- The corrected setpoints are increased in accordance with the curve above.
- Heat exchanger temperature is brought up to maximum value.

**Controlled DEFROST function:** Outside temperature > -5 °C

- The corrected setpoints are increased in accordance with a curve above.
- The heat exchanger setpoints are increased to at least 30 °C.

---

## Reactions to Termination of DEFROST Function

When the DEFROST function is active, only the rear window defroster, A/C functions and the temperature settings can be changed without switching off the DEFROST function. The DEFROST function is deactivated by pressing any button (except: temperature control knob, rear window defroster and REST buttons). When the DEFROST function is terminated by pressing the DEFROST button, the control panel settings (stored in memory) are reactivated.

A recirculated air function activated prior to DEFROST is deactivated, because recirculation and automatic A/C mode cannot be activated at the same time. This measure prevents the windows from fogging when the DEFROST function is switched off and further assisted by a delayed closure of the defroster flap.

If the system is coded for a hot climate, the recirculated air function is stored in memory along with the other settings (if selected prior to the DEFROST function).

## Solar Sensor Effect

The solar sensor allows the IHKA to compensate for sunlight that affects the temperature inside the vehicle. The solar sensors have an effect on air conditioning control. An increase in sunlight produces a shift in the functions listed below. The effect is opposite at night or when the vehicle enters a tunnel.

The solar sensor consists of two photoresistors (left and right), which register the varying intensity of the light rays. The sensor signals are interpreted in the solar sensor module and output to the IHKA control module (voltage range from 0 to 5V).

The effect of the solar sensor separately affects the driver's and passenger's side to influence the following air conditioning components/functions:

- Blower: The blower control curve is shifted (increased air flow compensation)
- Air stratification: The stratification temperature is shifted (increased temperature compensation)
- Flaps: The angle of the virtual flap is corrected (increased airflow/temperature compensation)



---

## Rear Window Defroster (HHS)

Pressing the HHS button activates the rear window defrosting and the function LED illuminates. The system is deactivated by pressing the button for a second time, or automatically when the defrosting period (10 or 17 minutes) expires. Pressing the button during cyclic operation starts the post-defrosting phase (5 minutes). The HHS function is independent of the other button activated functions of IHKA with the exception of the "OFF" function.

**Defrosting Phase:** After KL15 is switched "ON", the time period to optimize the rear window defrosting is set as follows:

<u>Outside Temperature</u>	<u>Heating Period (Defrosting Phase)</u>
> -15 °C	10 minutes
< -15 °C	17 minutes

The function LED remains on for the duration of the heating period.

**Cyclic operation:** The defrosting phase is followed by cyclic operation with 1/4 power for 30 minutes. This is cancelled by switching KL15 "OFF".

- 3 seconds ON / 9 seconds OFF.
- The function LED remains OFF during cyclic operation.

**Reactivation:** If the rear window does not remain clear during cyclic operation, pressing the button again activates the defroster at full power for another 5 minutes. The function LED lights up. This post-defrosting phase is followed by cyclic operation.

As of priority level 5 of the K-CAN message, low-voltage cutout by the power module is possible (protection effect of the power module). The HHS is controlled by the IHKA control module.

## Fault handling KL50

The communication defect "KL50 logically on" bus message will shut down the rear window defrosting and the duration of the KL50 active state is monitored. After 30 seconds of "physically on" this status is considered invalid and no fault message is entered in memory. The function will be "logically off" and the HHS circuit remains inactive.

---

## Rear Window Defrosting - ON/OFF Criteria During Starting

During starting (KL50 active), the rear window defrosting is "OFF". The status of the rear window defroster is transmitted by the IHKA control module over the K-CAN bus because:

- The power module switches the heated rear window on and off.
- The door modules control the outside mirror heating parallel with activation of the rear window defrosting.
- The navigation system requires the current flow status of the rear window (effects of the magnetic field).

## Wiper Parked Zone Heating

In order to prevent the wiper blades freezing to the glass at low outside temperatures, the wiper parked zone heating is activated depending on the outside temperature.

- < 3 °C Wiper parked zone heating ON
- > 6 °C Wiper parked zone heating OFF

Low voltage cutout of the wiper parked zone heating by the power module is possible. Switching conditions for shutdown are applied as of priority level 5 (K-CAN message).

## OFF Function

The OFF Function is activated by pressing the left air volume control knob. The functions switched OFF (current status is saved) when the button is pressed are:

- Function LED in OFF button comes on, all others off
- OFF at Control Display
- All flaps to 0%
- Refrigerant system switched off
- Blower off
- Auxiliary water pump off
- Temperature control switched off
- Interior sensor blower continues to run
- Sensor value is retained
- Water valves receive power to maintain the closed position



42-14-09

---

## Recirculated Air / AUC / Auto Recirculated Air

The RECIRCULATED AIR/AUC button has two functions.

- Changeover from RECIRCULATED AIR to AUC and vice versa
- Switch off RECIRCULATED AIR/AUC function (fresh air mode).



42-14-09

Changeover from fresh air mode to AUC or RECIRCULATED AIR:

### RECIRCULATED AIR / AUC Button

### Function

Press once

AUC function is activated -  
AUC LED "ON" and RECIRCULATED  
AIR LED "OFF"

Press twice

RECIRCULATED AIR function is  
activated - AUC LED "OFF" and  
RECIRCULATED AIR LED "ON"

Press three times

Return to fresh air mode - AUC  
and RECIRCULATED AIR LEDs  
both "OFF"

To avoid whistling noises from the IHKA, closure of the fresh air flap is delayed for 0.5 sec. and the stepper (MUX) motor for the recirculated air flap is activated.

## Recirculated Air Mode

The recirculated air function can be used to preserve the air quality inside the cabin in situations of poor outside air, when the vehicle is stopped in traffic, or when driving through tunnels. The recirculated air function is activated when the RECIRCULATED AIR/AUC button on the control panel is pressed or when AUC detects a recirculated air condition. The fresh air flap closes within a maximum of 1 second; the recirculated air flap opens in approximately 4 seconds.

The recirculated air function is not saved before the control module enters sleep mode, the function is not active following a reset.

**Note:** When in the recirculated air mode, the air conditioning is not automatically activated.

---

## Automatic Recirculated Air Control (AUC)

The IHKA measures air quality by analyzing the AUC-2 sensor signal. The AUC-2 sensor provides a PWM signal corresponding to the noxious-gas content. The sensor is provided 5V to activate the heating circuit (approx. 500 - 800 mW).

Each time the vehicle is started, the fresh air position is actuated for 30 seconds to allow proper sensor heating. Sleep mode does not cancel the AUC function.

Relative humidity inside the car can increase during a recirculated air phase, because the proportion of fresh air is low. This can cause the windows to fog, therefore recirculation in the AUC function is limited. The limitation time depends on whether the system is in heating or air conditioning mode:

- **Heating mode** - The recirculating air time period is limited to 4 minutes at outside temperatures  $> 6\text{ }^{\circ}\text{C}$  and is followed by 1 minute of fresh air.
- **A/C mode** - The recirculating air time period is limited to 12 minutes at outside temperatures  $> 6\text{ }^{\circ}\text{C}$  and is followed by 1 minute of fresh air.

## Automatic Recirculated Air

This special function rapidly cools the interior of the vehicle. When the occupant requests maximum cooling power from the air conditioning, cool air from inside the cabin is drawn back through the evaporator again. This results in a quicker temperature drop inside the vehicle.

This function initially operates for 12 minutes in the full recirculation air mode and then in partial recirculation air mode (fresh air 30% / recirculated air 100%). If this function is cancelled within the initial 12 minutes and reactivated, the function operates in the partial recirculation air mode. The automatic recirculated air function is switched ON and OFF according to the following:

### ON

A/C mode selected and the variable (Y)  $< -20\%$

### OFF

A/C mode is terminated  
The variable (Y)  $> -5\%$

---

## Stationary Functions

### Principle of Operation

The IHKA will operate features (when programmed) to enhance cabin comfort based on exiting heating and air conditioning systems and components. The IHKA Stationary Functions include: Residual Heat (rest) and Parked-car Ventilation.

### Residual Heat

The Residual Heat (rest) function uses the residual engine heat after it is switched off to heat the passenger compartment. When the REST button is pressed, the Residual Heat function is activated when KL15 is switched "OFF" and KLR is "ON". The auxiliary water pump is activated to circulate the hot coolant. The maximum "ON" time is 15 minutes.

The Residual Heat function active when:

- REST button is pressed
- Outside temperature < 15 °C
- Engine coolant temperature is > 70 °C
- Ignition switch is in position R (KL15 OFF)
- 15 minutes has not elapsed since KL15 was switched "OFF"



42-14-13

This function is deactivated when KL15 is switched "ON". When KLR is "ON", the AUTO buttons can also be pressed. The AUTO function is cancelled when KLR is switched "OFF", but the Residual Heat function will still remain active.

### *Settings with "Ignition Lock in Position R":*

Control panel remains active

- Temperature can be controlled
- Flap program available
- Blower speed adjustable
- Function lighting ON
- DEFROST, HHS, RECIRCULATED AIR/AUC and MAX-AC functions are not active

### *Settings with the "Ignition OFF":*

Control panel is inactive

- Temperature control is held
- Flap program and blower setting of independent heating are held
- REST function lighting is active

### **Parked-car Ventilation (SL)**

The Parked-car Ventilation blows ambient air into the passenger compartment to lower the interior temperatures. The air enters the passenger compartment through the vent outlets in the instrument panel, which can be adjusted for both direction and flow (must be open for the system to operate). The system remains on for 30 minutes. The system can be switched on and off manually.

The *outside temperature must be > 50 °C* to activate this function. Using the Control Display, the Parked-car Ventilation function has 2 control options: Direct (manual) operation and Timer programming.

#### *Activating and Deactivating Manually:*

- Ignition in position "KLR"
- Select "Indep. vent." on the second page of the "Climate" menu and confirm to activate
- Select "Indep. ventil." a second time and confirm to deactivate

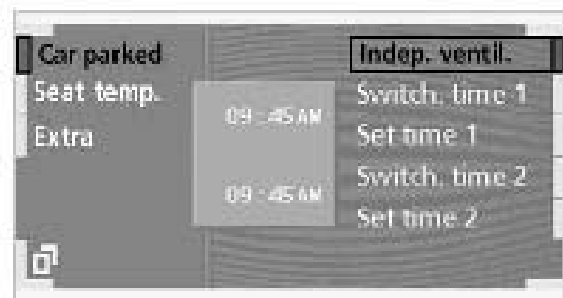

42-14-15

#### *Timer Programming (two available times):*

- Ignition in position "KLR"
- Select "Indep. vent." on the second page of the "Climate" menu and confirm
- Select "Set time1" / "Set time 2" and confirm
- Enter the desired time by turning the Controller and press to confirm

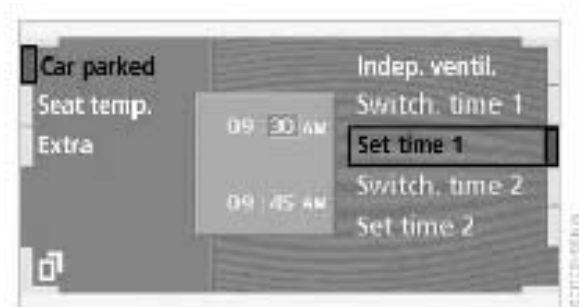

42-14-22

### *To Activate Timer:*

- Select "Switch time 1" / "Switch time 2" and confirm

The Parked-car Ventilation is only available for activation within the subsequent 24 hours. After this the time will have to be reconfirmed.

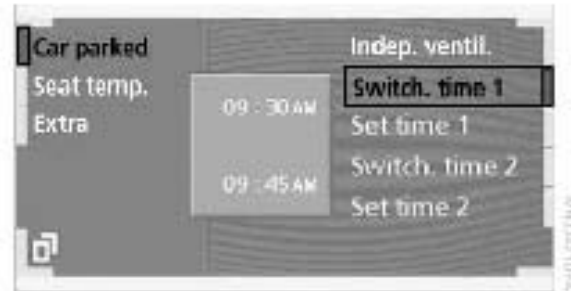

42-14-23

### *Terminal R "ON" (Control Panel is Active):*

- Temperature control OFF (water valves closed)
- Flap program manually selectable
- Blower manually adjustable
- Function lighting ON
- Function buttons not active

### *Terminal 15 "OFF" (Control Panel is Inactive):*

- Temperature control: OFF (water valves closed)
- Flap program (0% = flap closed / 100% = flap open)
  - Warm air left and right 100%
  - Recirculating air 0%
  - Defrosting 0%
  - Footwell left and right 0%
  - Cold air left and right 100%
  - Rear seating area left and right 0%
  - Fresh air 100%
  - Blower set to 50%
- Function lighting OFF

**Note:** The stationary functions are registered with the power module and are subject to deactivation by the power module (priority lever consumer shutdown > 6). The power module continuously monitors the battery state of charge while the Parked-car Ventilation function is active. When the power module issues the shutdown signal for the independent consumers, the IHKA will shut down the Parked-car Ventilation and it will not be reactivated.

The IHKA will send a CAN message "status air conditioner Parked-car Ventilation" with the "INDEPENDENT VENTILATION not active" information to the Control Display. The Control Display responds by updating the on screen display.

## Non-Air Conditioning Functions

### Rear Window Roller Blind Control

The IHKA controls the roller sun blind for the rear window and provides the OPEN/CLOSED information to the side window roller sun blinds.

### Principle of Operation

The rear window roller blind is controlled by K-CAN messages sent by one of the door modules. The IHKA distinguishes between short and long actuation of the button.

Short actuation of the button (< 750 ms) will cause the rear window roller blind to be activated. If the button is pressed longer, a request is sent to the door modules to move the side window roller blinds in the same direction as the rear window roller blind.

When the motor of the rear window roller blind is stopped short, the motor will move in the opposite direction (OPEN or CLOSE), depending on the previous detected limit position. The direction of motor rotation is reversed when the button is pressed while the motor is in operation. The motor continues to receive the drive signal until it stops.

The first time the button is pressed after the engine is started (and KLR active), the motor will attempt to move the roller blind down, because the current position is not known. If the motor immediately blocks, the direction of rotation is reversed. To protect the motor, the drive signal is cancelled after 15 seconds (or current draw exceeds 8 amps).

### Actuation and Fault Recognition

The illustration shows the motor of the rear window roller blind.

- S - Switches in doors
- TM - Door module
- CAS - Car Access System
- K CAN P - K bus periphery
- K CAN S - K bus system
- mC - Micro-controller
- ECU - IHKA control module
- D - Diagnosis output
- S1...S4 - Electronic switches
- A - Rear window roller blind "OPEN" signal
- B - Rear window roller blind "CLOSED" signal

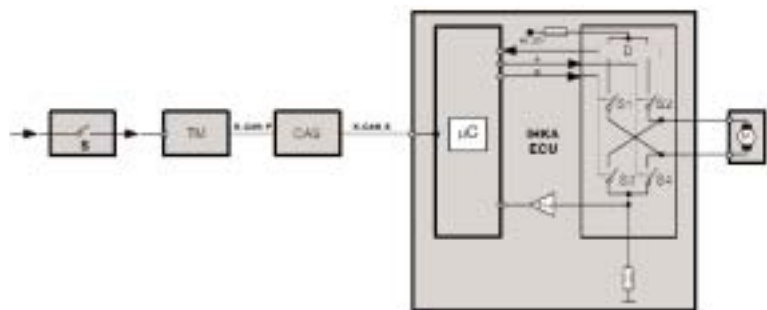





---

## Coding

The following coding information is factored into the IHKA control module:

- Vehicle type variants
- Engine versions
- Specifications for national markets
- Special equipment
- Control module variants (independent heating, RHD/LHD cars)

The coding data is uploaded to the memory (EEPROM) of the IHKA control module, but is not active until the control unit has been reset.

## Control Module Identification

The data written into the memory chip for control module identification is:

- BMW part number
- BMW control module version number
- BMW coding index
- BMW diagnosis index
- BMW variant number
- Manufacturer's date of production
- Manufacturer's catalogue of messages
- Manufacturer's software version
- Manufacturer's standard core version
- Manufacturer's reserve
- BMW change index
- BMW test stamp

Overview of BMW control module versions:

<u>Version for IHKA Manufacturer</u>	<u>Control Module Number</u>
IHKA High without roller sun blind	03
IHKA High with roller sun blind	04

## Key Memory

The custom settings of four different radio control keys can be saved in memory (EEPROM) after KL15 is switched "OFF". One of these four sets of settings is reactivated when KL15 is re-energized with the corresponding key. The last setting is activated either when the engine is started with the workshop key or if the information for the key number is incorrect. The information for the key number is sent as a K-CAN message.

---

Following a reset (KL15), the IHKA sends a message to the CAS requesting what key is currently in the initialization phase. Driver specific data is stored in memory blocks (EEPROM) for the total of four distinctive radio control keys.

When one of these radio control keys is used, the appropriate memory block is called and the contained settings are activated. A fifth memory block contains default settings (in case a valid key is not recognized).

The following data is stored in each of the five memory blocks:

- Temperature, left
- Air distribution program, left
- Air distribution, bottom left
- Air distribution, top left
- Blower, right
- Air stratification, right
- Air distribution, middle right
- Blower, left
- Air stratification, left
- Air distribution, middle left
- Temperature, right
- Air distribution program, right
- Air distribution, bottom right
- Air distribution, top right

Active function:

- Always saved: AUC, AC, OFF
- Can be activated by coding:
  - Start with AUTO
  - Start with AC
  - Higher/lower blower characteristic

## **Vehicle Memory**

Vehicle Memory includes all actions permanently saved in the IHKA before the control module enters sleep mode and are reactivated after a reset (KL15).

### ***Saving Control Panel Status***

- Terminal 15 ON, engine stopped. Each change to the control panel settings is saved approximately 1 second later in the control module.
- Terminal 15 ON, engine running. Each change to the control panel settings is saved approximately 10 seconds later in the control module. DEFROST, MAX AC, RECIRCULATED AIR and HHS are cleared when the consumer is switched off.

---

**Exception:** Hot-climate version (can be coded). The RECIRCULATED AIR or MAX AC function, if activated before shutdown, is saved with the other settings.

### *Coding Variants for Control Panel Functions*

- Hot-climate version. When this version is coded the recirculated air function (if active) it is saved to memory (EEPROM) along with the other data when the control module enters sleep mode and is immediately available the next time the engine is switched on.
- Off lock. When this version is coded the OFF function is deleted when the control module enters sleep mode, the next time the engine is switched on the functions active before the OFF button was pressed are automatically reactivated.
- Automatic variants and automatic air stratification. The IHKA offers three variants for handling the AUTO function. There are also three different modes of setting air stratification to 50% when the AUTO function is switched on.

### *Custom Settings*

The INDIVIDUAL program (EEPROM) can be used to save a data set with the following user-configurable flap settings for each side:

- Air distribution, head
- Air distribution, chest
- Air distribution, feet

The data sets for the INDIVIDUAL program are saved when the "NO PROGRAM" option is active and the memory button is pressed. The flap position settings are reactivated as soon as the user selects the "INDIVIDUAL" setting on the Control Display.

### **Power Module Influence**

The power module uses the CAN message (power management) battery voltage signal "Control peak-reduction priority" to control consumer shutdown by priority levels. The IHKA system responds to these priority signals by implementing the following measures:

- Priority 6 measures
  - Wiper parked zone heating OFF
  - Rear window defrosting OFF (applies to normal operation only, not in cyclic operation)

- Priority 5 measures
  - Wiper parked zone heating OFF
  - Rear window defrosting OFF (applies to normal operation, not in cyclic operation)
- Priority 4 measures
  - Blower set to max. 50%
- Priority 1 measures
  - Wiper parked zone heating OFF
  - Rear window defrosting OFF (applies to normal operation, not in cyclic operation)
  - Blower set to max. 25% (at this time the blower is shut down)
- When the "Status of independent consumers" is received = SHUTDOWN
  - Parked-car Ventilation OFF
  - Residual heat OFF

**Note:** The DEFROST function always has 100% blower power available (safety relevant function).

## Sleep / Wait / Power Down Modes

### *Sleep Mode*

To achieve the IHKA control module required standby current consumption (< 100 mA), network management forces it to enter sleep mode by isolating it from terminal 30.

### *Wait Mode*

Conditions for wait mode:

- The control module run on time must be expired, 2 run on times are possible.

<u>Run on time of the control unit</u>	<u>Terminal 15</u>	<u>Conditions for Residual Heat</u>
3 minutes	OFF	not satisfied
15 minutes	OFF	satisfied

- The run on time for the water valves must be expired (fuel station effect can be coded). The control module enters a wait routine and is de-energized when all run on timers have timed out.

---

## Individual Sensor Values / Actuator Outputs

Interior temperature sensor	Failsafe value: 20 °C
Heat exchanger temperature sensor	Failsafe value: 55 °C
Evaporator temperature sensor	Failsafe value: 2 °C
Ventilation temperature sensor	Failsafe value: 20 °C
Pressure sensor	Voltage supply: 5 V $\pm$ 0.25 V Output voltage: 0 V...5 V

The pressure sensor outputs a voltage that is linear to the refrigerant pressure (from 0.4 V to 4.6 V range). The refrigerant compressor is switched off if pressure is excessive.

Solar sensor	Voltage supply: 5 V $\pm$ 0.2 V Output voltage: 0 V...5 V
AUC-2 sensor	Voltage supply: 5 V $\pm$ 0.25 V Output voltage: 0 V to 5 V
Refrigerant compressor control valve	
Resistance of control valve at +20 °C:	10.6 W $\pm$ 0.5 W
Resistance of control valve at +70 °C:	14.5 W $\pm$ 0.5 W
Auxiliary water pump	
Switch on current:	approx. 5.0 A/100 ms
Rated current:	1.5 A
Fresh air flap / rapid action motor	8 ohms $\pm$ 7% (500 Hz)
Bus stepper motors	100 ohms (200 Hz)

---

## Review Questions

1. List the gasses detected by the AUC-2 sensor. \_\_\_\_\_

2. Explain how the refrigerant compressor output is varied. \_\_\_\_\_

3. List the refrigerant compressor "Run In" procedure. \_\_\_\_\_

4. Where is the blower motor and blower control module located? \_\_\_\_\_

5. What are the "Master" function controls on the control panel? \_\_\_\_\_

6. Explain the "Y" factor. \_\_\_\_\_

7. How is the temperature increased during air conditioning operation? \_\_\_\_\_

8. List the functions that apply to heater operation when the coolant is cold. \_\_\_\_\_